

LEADER PAGE & MINI LEADER PAGE PROOFERS

with manual loading and automatic unloading



Dough proofer with manual loading and automatic emptying into an add-on moulder.



Leader Page semi-automatic group:
Intermediate proofer + Add-on moulder.

STANDARD

- **Small size and maximum capacity:** optimization of space in your bakery.
- **Ergonomically positioned work surfaces:**
 - Moulder table height: 93 cm
 - Rounding table height: 83 cm
- **2mm double-thickness steel sheet metal sides:** optimum resistance and rigidity.
- **Smooth internal side surfaces:** no retention of flour dust.
- **Advancement of the frames using push buttons:**
 - Very simple to use and ergonomic
 - Allows continuous loading of the moulder
- **Frames removable with screwed axles:** each frame can be removed independently at the loading area without moving the proofer.
- **Mechanical safety by breaking screw:** guarantees mechanical protection of the machine.
- **Nyltex double thickness pockets with no Velcro:** extra-strong fabric pockets with low humidity retention and no bacterial retention areas.
- **Moulder connection terminal and divider socket:** to power the ancillary devices.
- **Possibility of emergency drive via the transmission shaft:** allows the swing to be emptied in the event of a power cut.
- **Electrical box separate from the engine block:** allows access to mechanical areas without risk of electric shock for users.
- **Machine mounted on 6 casters including 2 brakes:** easy to move thanks to the Ø80 polyamide casters.
- **Rubber bumpers** at the rear for protection against impacts with the wall.

BRONZE

- **Hygiene protection kit (UV germicide lamps + 2 air extractors):**
 - Germicide UV lamp with automatic timer
 - 2 air extractors to dry the pockets
- **GoFirst (Choice and Search for 1st frame):** allows you to define at any time a reference frame among all those of the machine, and to program an automatic return to this frame, without prolonged button pressing.

SILVER

- **Felt-covered rounding work shelf:** specially reinforced, can be manoeuvred with one hand.
Maximum permissible load: 20kg

GOLD

- **Actuation pedal:** allows moving the swings forward with your foot. Both hands remain free to work.

	STANDARD	BRONZE	SILVER	GOLD
Hygiene kit		✓	✓	✓
GoFirst		✓	✓	✓
Rounding work shelf			✓	✓
Actuation pedal				✓

OPTIONS

- **Two sensitive buttons:** replace push buttons and provide ease of use. Less risk of impact than a button.
- **Synthetic felt gutters:** possibility to replace Nyltex with felt.
- **Delivery of disassembled proofer:** for easier installation in bakeries with limited access.
- **Electrical change** if other than 380V/50Hz.

OVERVIEW

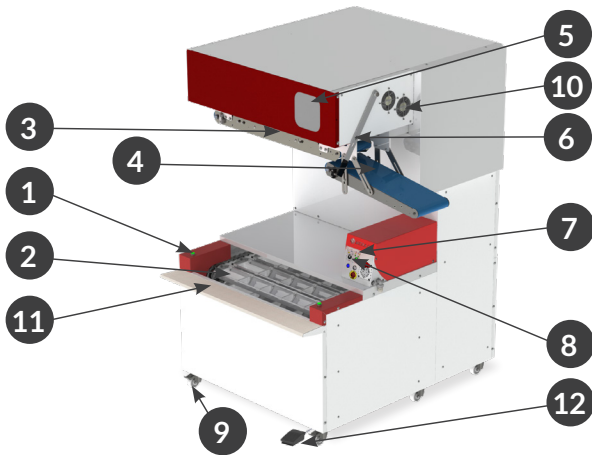

1. Swing frame actuation push-buttons
2. Tray proofers
3. Discharge conveyor belt
4. Transfer conveyor belt
5. Window to check trays before tipping
6. Disengageable tipping lever
7. GoFirst option
8. 3-position button: Loading/Discharge/Germicide option
9. 6 x Ø80mm castors, 2 with brakes
10. Hygiene kit option
11. Rounding table option
12. Actuation pedal option

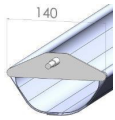

Frame width 14cm
recommended for baguettes
and breads up to 550g

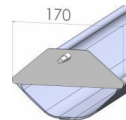

Frame width 17cm
recommended for baguettes
and breads up to 1kg

CAPACITIES / DIMENSIONS

References	Total number of useful swing frames	Swing frames width* (in cm)	Capacities* in			Depth (in cm)	Width (in cm)	Useful width (in cm)
			Baguettes (330g)	Loaves (550g)	Large loaves (900g)			
PAGE-LEA-56/43	43	17	387	344	258	154	167	140
PAGE-LEA-70/54	54	14	432	378	-	154	167	140
MINI PAGE-LEA-56/43	43	17	301	344	172	154	127	100
MINI PAGE-LEA-70/54	54	14	378	378	-	154	127	100

(*): For information only: may vary according to type of dough (% yeast, dough temperature, room temperature, fermentation time, ...).

LEADER PAGE

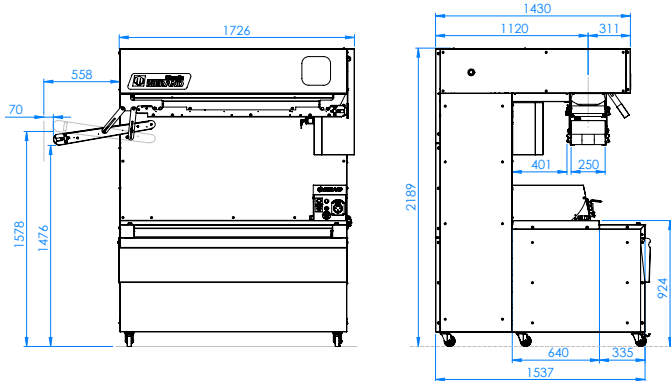

MINI LEADER PAGE

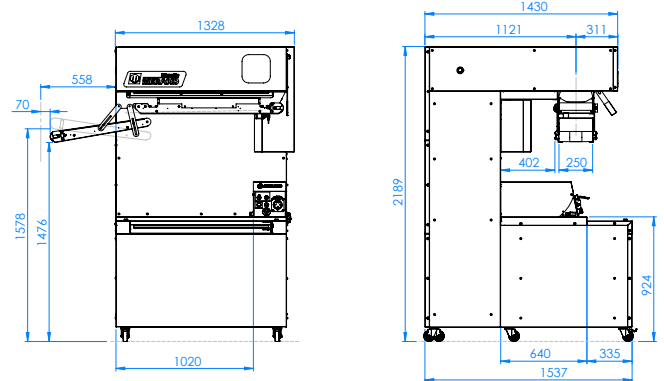

WEIGHT / PACKAGING

Weight:

- Leader PAGE - 530kg
- Mini Leader PAGE - 460kg

Packaging of dismantled proofers:

- 1 crate: 250cm x 110cm x Height 215cm
- 1 crate: 180cm x 80cm x Height 125cm

Packaging of proofers mounted on pallets and wooden protection:

- Leader PAGE : 186cm x 164cm x Height 225cm
- Mini Leader PAGE : 146cm x 164cm x Height 225cm

ELECTRICAL SPECIFICATIONS

400 Volts / 50 Hz / 0,5 kW max. / 2 A max.
 400 Volts / 60 Hz / 0,6 kW max. / 2 A max.
 230 Volts / 50 Hz / 0,5 kW max. / 3,4 A max.
 230 Volts / 60 Hz / 0,6 kW max. / 3,4 A max.
 Power supply: 5m long cable with male TRIPHASE + Earth + Neutral

HYGIENE / SAFETY

The proofers comply with:

- EU "Machinery" directive 2006/42/EC
- The French Labour Code

Z.I. de la Turbanière

BRECE • 35530 • FRANCE

+33 (0)2 99 04 15 30 • salesdpt@merand.fr • www.merand.fr