

MANUAL PROOFERS

The MERAND manual dough proofer comes after the division step; it creates a stable atmosphere which protects the dough pieces from drying out and relaxes the dough to facilitate stretching in the moulder.

Our dough proofer is a sure value on the market, combining what makes MERAND machines strong: robustness, ergonomics, compactness, ease of cleaning, accessibility for maintenance and ease of use.



STRONG POINTS

- ✓ Very compact
- ✓ Robust
- ✓ Easy to clean
- ✓ Accessible for maintenance
- ✓ Easy to use



CHARACTERISTICS

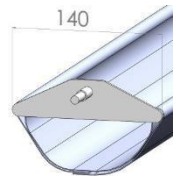

***Frame width 14cm**
recommended for baguettes
and breads up to 550g

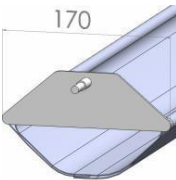

***Frame width 17cm**
recommended for baguettes,
breads, and large loaves up to 1kg



Référence	Number of swing trays	Width of swing trays* (in cm)	Capacities* in			Depth (in cm)	Width (in cm)	Useful width (in cm)
			Baguettes (330g)	Breads (550g)	Large loaves (900g)			
PAGE 26/170	26	17	260	208	182	118	167	140
PAGE 32/170	32	17	320	256	224	137	167	140
PAGE 33/140	33	14	330	264	-	118	167	140
PAGE 40/140	40	14	400	320	-	137	167	140
MINI PAGE 20/170	20	17	160	160	100	98	127	100
MINI PAGE 26/170	26	17	208	208	130	118	127	100
MINI PAGE 26/140	26	14	208	182	-	98	127	100
MINI PAGE 33/140	33	14	264	231	-	118	127	100

*Capacities given as an indication, several parameters can influence the capacity, in particular: the percentage of yeast, the temperature of the dough, the tightness of the dough pieces, the fermentation time, etc.



CHARACTERISTICS



Interior sheets with smooth surface

- Prevent flour infiltration and retention. This makes cleaning easier and ensures optimal hygiene.



Dismountable frames with screwed axles

- No need to dismantle the structure of the dough proofer.
- Each frame can be removed independently at the loading area without moving the proofer.
- Easy and quick cleaning of Nyltex gutters and easy maintenance.



Nyltex double-layered gutters without velcro

- Highly resistant, designed by MERAND.
- Its very fine mesh allows the dough to breathe, thus avoiding any sticking
- Air circulation makes the gutters dry very quickly.
- Washable in a washing machine.
- A single sleeve that slips easily into the removable frame.
- No velcro to avoid flour retention near the dough pieces and to ensure durability (even after washing it in a washing machine).



Possibility of emergency drive via the transmission shaft

- Allows emptying the dough rest in the event of a power failure.



CHARACTERISTICS

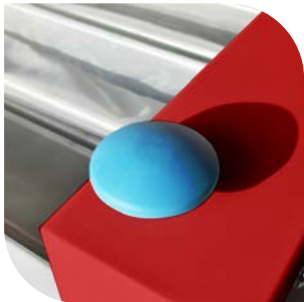

Push buttons for armature advancement

- Two buttons (left and right) to limit operator movement.
- Located at the front of the machine, no need to bend over.
- Horizontal position for better ergonomics.



Electrical connections

- A moulder connection on terminal block and divider connection on front socket.
- It allows powering the trio from a single wall outlet, reducing cables lying around for easier cleaning.



Mechanical parts and electric motors placed on the table

- Facilitates access for technician interventions
- Housed in different boxes, which allows access to mechanical areas without risk of electric shock for users.



Machine mounted on 4 casters including 2 brakes

- Easy to move thanks to the Ø80 polyamide casters.



OPTIONS



Two touch-sensitive buttons

- Replace push buttons for user comfort.
- Less risk of damage compared to a push button.



Hygiene Kit

- Includes two air extractors with germicidal UV lamps.
- Ensures impeccable hygiene.



Impulse pedal

- Allows advancing the proofer with the foot.
- Keeps both hands free for work.



Delivery of assembled dough proofer

- To save time during installation when accessibility allows.



OPTIONS



Folding felt-covered rounding shelf

- Easy to set up and retract with one hand, without a crutch.



Synthetic felt gutters

- Possibility to replace Nyltex with felt.



GoFirst - Choice and Search for 1st swing

- Allows you to define a reference swing at any time among all those on the dough proofer, and to program an automatic return to this swing, without a prolonged button press.
- No downtime pressing a button to wait for the 1st swing.
- No waiting time to return to the 1st swing between 2 productions.
- Daily wear is distributed over the different swings.



LAYOUT



PAGE manual proofer

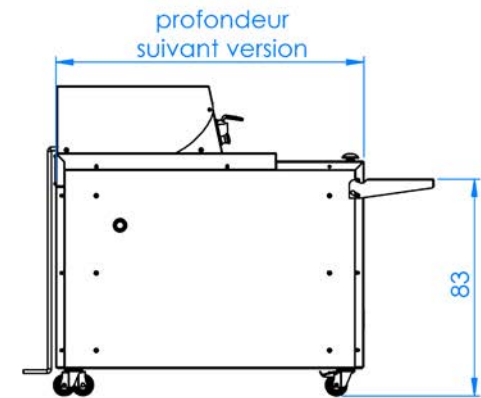
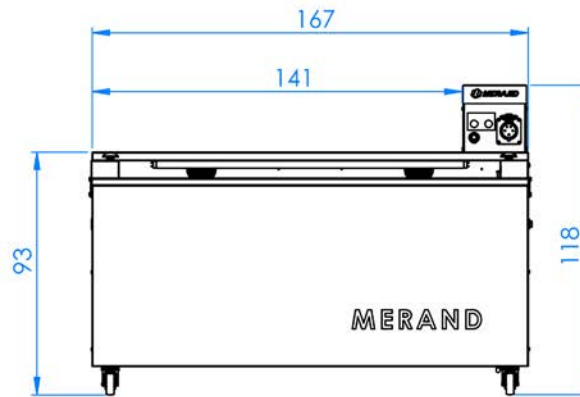

Mini PAGE manual proofer

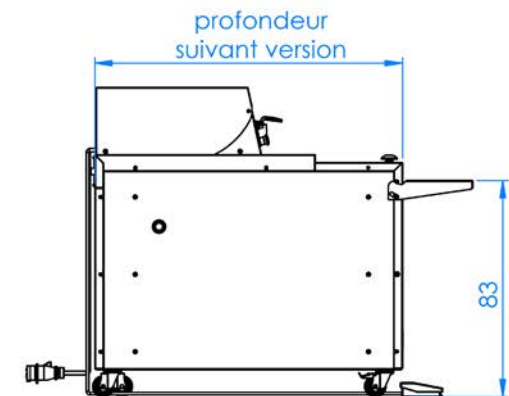
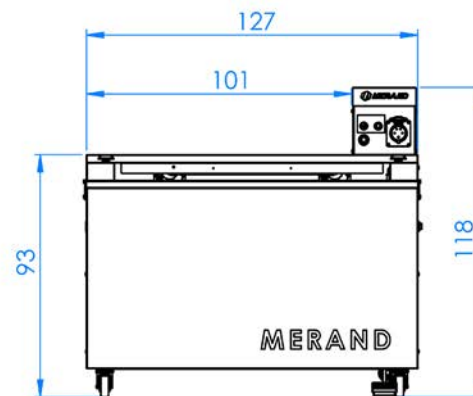

LAYOUT

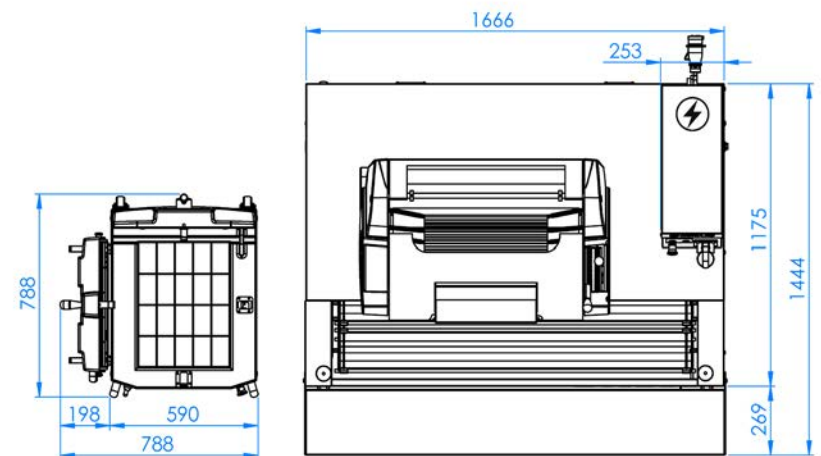
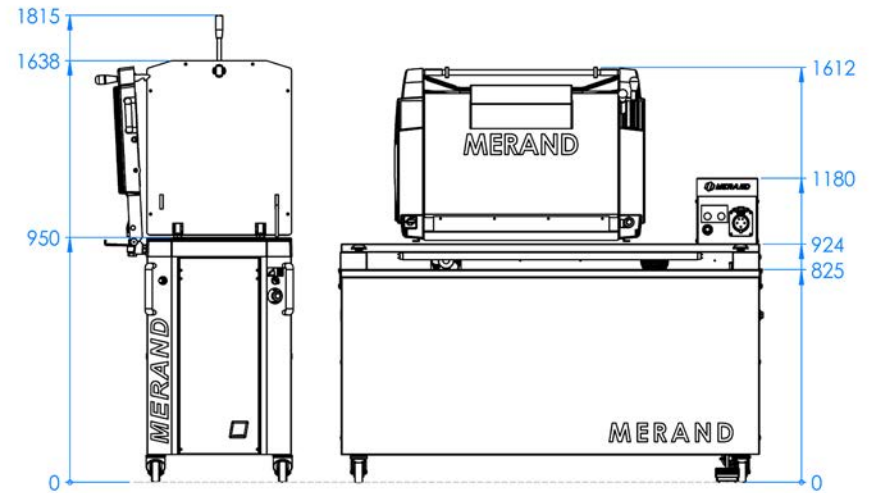

MERAND RANGE OF AUTOMATIC BREAD LINES

RheoPan



EasyLine



FlexiLine

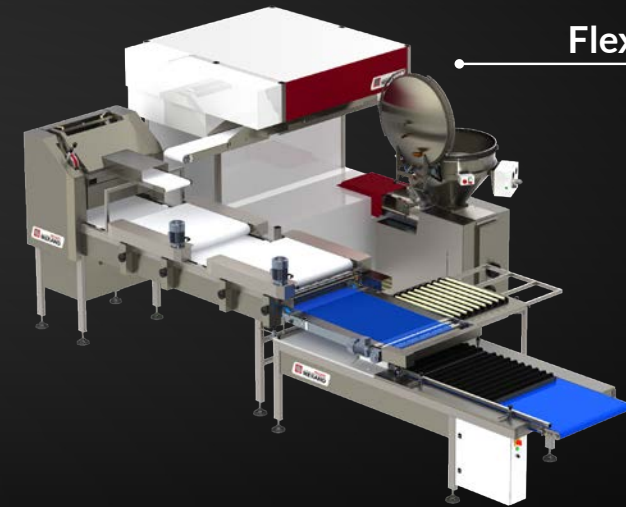

Scoring Line



Kraft Line



Artisan Range



Z.I. La Turbanière - 35530 - Brécé - France
+33 2 99 04 15 30 - salesdpt@merand.fr
www.merand.fr/en/